

MEASURING SWATH WITH SWATH BOARDS, DYE, AND CALCULATOR BOND PAPER ROLLS



Overview:

This document describes a method for measuring spray swath from sprayers. It can be used with ground sprayers, UAV/drone sprayers, and manned aerial sprays by helicopter or airplane. It uses inexpensive rolls of 3" (78 mm) bond paper (not thermal or NCR paper), such as those used by cash registers or calculators, simple DIY collecting boards (swath boards), and a visible dye at sufficient concentration to be able to see each hit clearly with the naked eye. The consumables, paper rolls and dye, can be collected and stored as a durable record of the swath, or scanned in a Swath Gobbler™ Swathing tool to create a digital record and report.

The Advantage of this method is threefold:

1. It is a complete, correlated and ordered record of the cross-section of the swath. This greatly reduces the risk of sampling bias or underestimation of the Coefficient of Variation (CV) by sampling with small cards at 1 meter or similar intervals. It is also impossible to get a continuous roll mixed up, unlike sampler cards.
2. It is a durable record compared to water sensing paper (WSP) due to the fact that humidity will not continue to develop the sampler. The rolls can be stored for years.

3. It is inexpensive and fast. WSP can cost \$20-50 dollars or more per swath characterization. A roll of paper and a few milliliters of dye is only a few dollars. If you want to scan for a digital record, The rolls can be scanned at a rate of about 2 feet (.6 meter) per minute.

Why Swath?

Manned Aerial applicators have relied on swathing for years, knowing that just because they have an equal array of quality unclogged nozzles across their boom doesn't mean they will lay down a uniform swath. Applications from the air are complicated and not easy to predict. Even ground sprayers may not be as uniform in the field as they look on a test bench. The faster and higher the boom, the more that "wake effects" can alter the uniformity of the spray. What is wake effect? Think of the wake behind a sprayer as similar to the wake behind a boat, but more 3 dimensional. Does it impact spray distribution and swath? Absolutely.

UAV sprays, especially multicopter sprays, are more complex and less understood than manned aerial and ground based sprays. This makes actual swath measurement and validation even more important.

Useful Definitions

"Use Case"

All of the variables in a spray application become a "Use Case". For a given use case, a spray swath should be reasonably repeatable. If it proves otherwise, there are likely other variables not being considered in the Use Case. There are a long list of variables that could be considered as part of the Use Case that may impact swath width and quality, here are the main ones:

1. **Droplet spectrum** (may vary with variable rate systems)
2. **Application rate**
3. **Travel speed**
4. **Model of UAV**
5. **Percent fullness of tank**
6. **Height of application** above crop
7. **Downwash energy** per area sprayed (a function of factors 3, 4, 5 and 6)
8. **Crop canopy** characteristics
9. **Ambient weather** including cross-wind, temperature and relative humidity.
10. **Pitch:** The degree of sideways angle the UAV may be flying at to combat crosswind, which can shift swath.

- 11. Roll:** the degree of forward or rear-lean that the UAV uses to accelerate or decelerate. This is typically dynamic and can lead to off-swath deposition at the beginning and end of the swath as the drone “angles in” to accelerate and “angles back” to decelerate and stop.
- 12. Orientation:** some UAV control software allows forward and reverse flight. Investigation has shown that changing orientation has a measurable effect on swath.

“Hits per Area”

This is the number of individual droplet stains on the sampler per area, usually per centimeter or inch squared. Higher hits per area in swath can imply higher quality coverage or more uniform distribution over the plant surface, important for contact materials. If the hits per area remain high downwind of the swath, it may imply either “swath shift” (see below) or that a drift event may have occurred.

“Percent Area Covered”

This is a simple measurement of the total number of pixels with dye divided the total number of pixels in the image. It can be a single large deposit or many small ones. Higher percent area covered can correlate to higher mass transfer, which is *generally* more useful.

“Swath Shift”

Crosswinds can move the spray swath. Each 1 mile per hour of wind is 1.47 feet per second. Each kilometer per hour of wind is .28 meters per second. UAVs tend to apply much higher than groundbased sprayers, so it is reasonable to expect that crosswinds will have an effect on swath. If not understood and compensated for, this swath shift can move off-target and become spray drift.

Intended Use of This Method

This method provides a complete record of the spray swath in a quickly deployable and collectable way. It can also be used to show swath displacement due to wind and make qualitative assessments of nearfield off-target deposition (spray drift). Using the paper rolls, dye, and swath boards may be enough for an applicator to evaluate and understand their Use Case and the resulting swath. Deploying the swath boards, setting, spraying and collecting the paper generally can be done in 15-20 minutes for the first swath, and 5-10 minutes for each repeat evaluation. Swath papers are durable, they can be rolled and stored indefinitely, then scanned later if desired.

This document does not explain Swath Gobbler use; there are other documents for that on the SG website, however we will note that one can do about 40' (13 meters) in 10-12 minutes for a full scan. If sections are skipped, and say the scan is done every 10 cm, the paper can be evaluated much faster. It is relatively high precision, (1200 DPI image capture) with the single pixel size of about 25 microns, so the gross majority of the droplets in an agricultural spray should be able to be measured if they deposit.

Limitations of the Bond Paper Rolls

This method is designed to elevate speed and reasonable repeatability as the two primary considerations. Bond paper is a less precise collector than Kromekote or other more technical scientific surfaces, as it is less designed to control wicking compared to glossy clay emulsion surfaces, so if very high precision is required for a study, this method may have limitations.

If Digital Data is Desired

If the swath is analyzed with a Swath Gobbler, the device outputs two measurements: **Percent Area Covered** and **Hits per Unit Area**. It deliberately does not calculate a droplet size distribution of the stains. This is due to the fact that any Droplet Size Distribution (DSD) calculated from paper collectors relies on assumptions that cannot be validated, such as the fact that all droplets are captured and detected, spread factors are known for that application condition and similar for all stain sizes, there are no multiple hits, etc. None of those assumptions are true, so any calculation of DSD from stains on paper is just a number, and a dangerous one in that it is highly likely to be misinterpreted and misused.

Suggested Basic Swathing Procedure

Supplies

To take a continuous swath measurement, you will need three things:

- 1. Bond paper rolls.** It must be bond paper (designed to be printed on with ink), not thermal paper or No Carbon Required (NCR) paper. If you are going to scan it in a Swath Gobbler it must be 3" (76 mm wide).
- 2. Dye.** Application Insight supplies a liquid food grade blue dye that is used at .15 to .3% volume to volume. Any dye that makes a strong visual mark can be used. A few other examples are Rhodamine WT, Beetroot juice, Blue pond dye (aquashade). Test your dye and concentration. Spray a little in a test bottle on some paper. Look at the mark closely. If you can easily see the definition of the droplets under a magnifying glass, you should easily be able to threshold and analyze the mark.

- Speed Track / Swath Boards** or some other way to hold the paper. If analyzing a UAV, the downwash will blow paper around and give inaccurate readings. Speed Track Kits consist of a set of 13 connecting tracks, engineered to hold paper firmly as drones fly over. Load paper in seconds with innovative sled design. Available for order at <https://www.betterfieldstudies.com/speedtrackkit>. Alternatively, swath boards hold the paper flat so that a comparable measure can be taken.

Making the Swath Boards

Plans for a basic swath board design are at the end of this document. Choose PVC or other plastic trim boards that won't retain dyes. These can be easily washed and used many times without risk of altering data. 100 mm/ 4" PVC trim boards can be purchased at most home improvement stores. Alternatively, vinyl cove molding is also readily available and more portable.

Basic Suggested Swathing Strategy

The images below show a simple strategy that yields a lot of swath information.

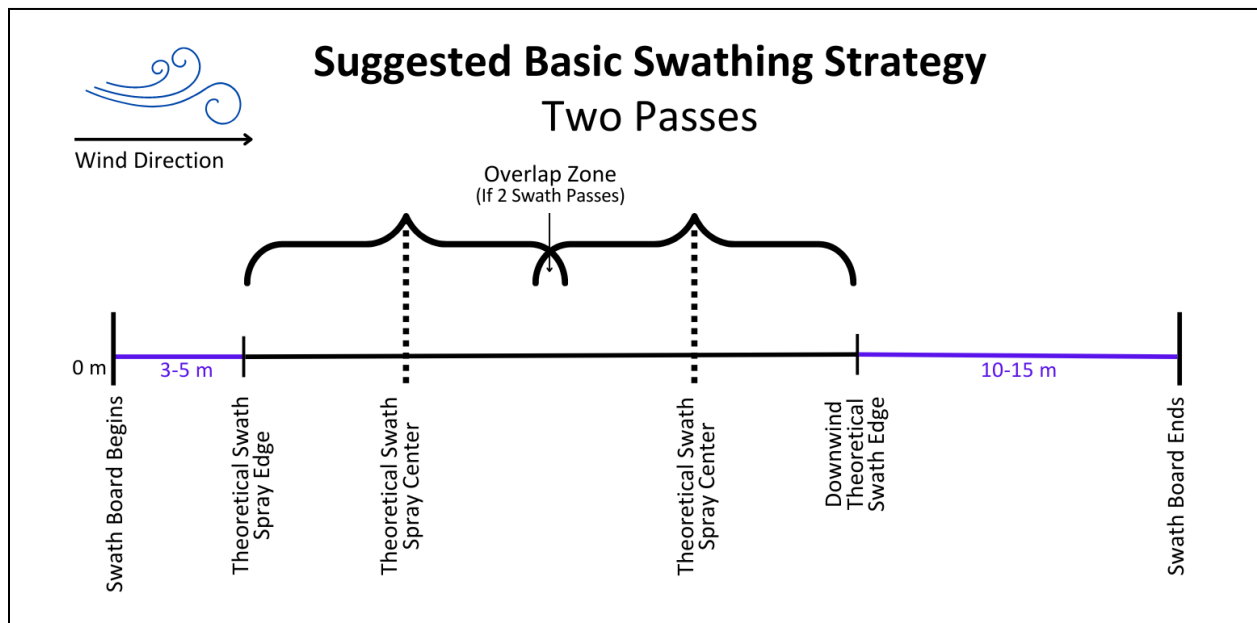

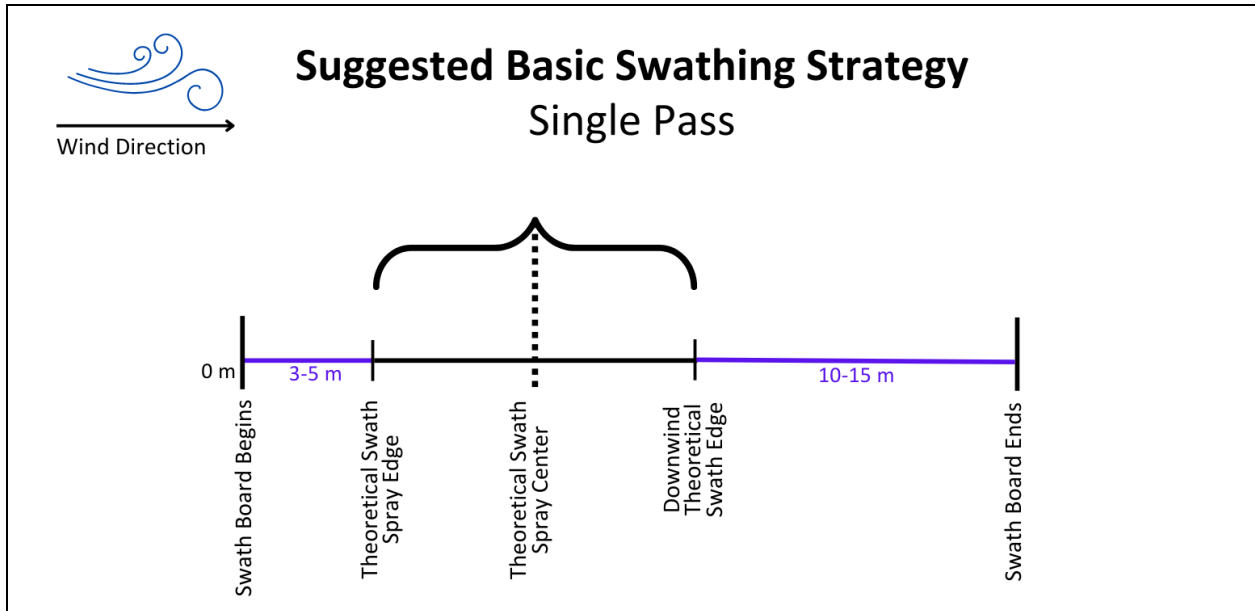

- **Upwind:** 3-5 meters of paper should be placed upwind of the first pass. The goal should be to get to 0% coverage/0 hits per area. If you are not getting to zero coverage, re-consider the Use Case, re-examine meteorological conditions, or extend the length of paper.
- **Swath Zone:** In the above image, parallel passes are made, this is usually a down and back scenario. The Flight lines should be marked on the paper as a reference and noted. This will show:
 - If the estimated swath width is correct
 - If the UAV is behaving differently in each direction, (a common occurrence)
 - If the overlap is correct to produce the desired uniformity/Swath CV.
 - Passes can also be separated if quantification of each pass is desired. In this case, increase the distance between the passes 4-5 meters or as needed.
- **Downwind Zone:** This should be 10-15 meters of paper downwind of the Swath Zone. This is where swath shift will register, and if there was a likely drift event due to factors in the Use Case, this area will register that. If at 15 meters there is still substantial deposition, change the Use Case or extend the paper as needed to get to zero or near zero reads.

Interpreting the Downwind Zone

It is typical to have some deposition in the downwind zone even in a technically excellent spray, this would be the normal overlap in-field. The Green line below would represent that. Percent Cover will drop off very quickly, but if the Hits per Area remain high, that indicates detrainment of fines from the spray column and a potential for a spray drift event. The further afield the

readings remain high, the higher the risk. This method does not substitute for a quantitative drift study, but can be used as an inexpensive “first pass” to determine if more precise, expensive and time consuming methods are required.

Typical Downwind Scenarios 10-15 m

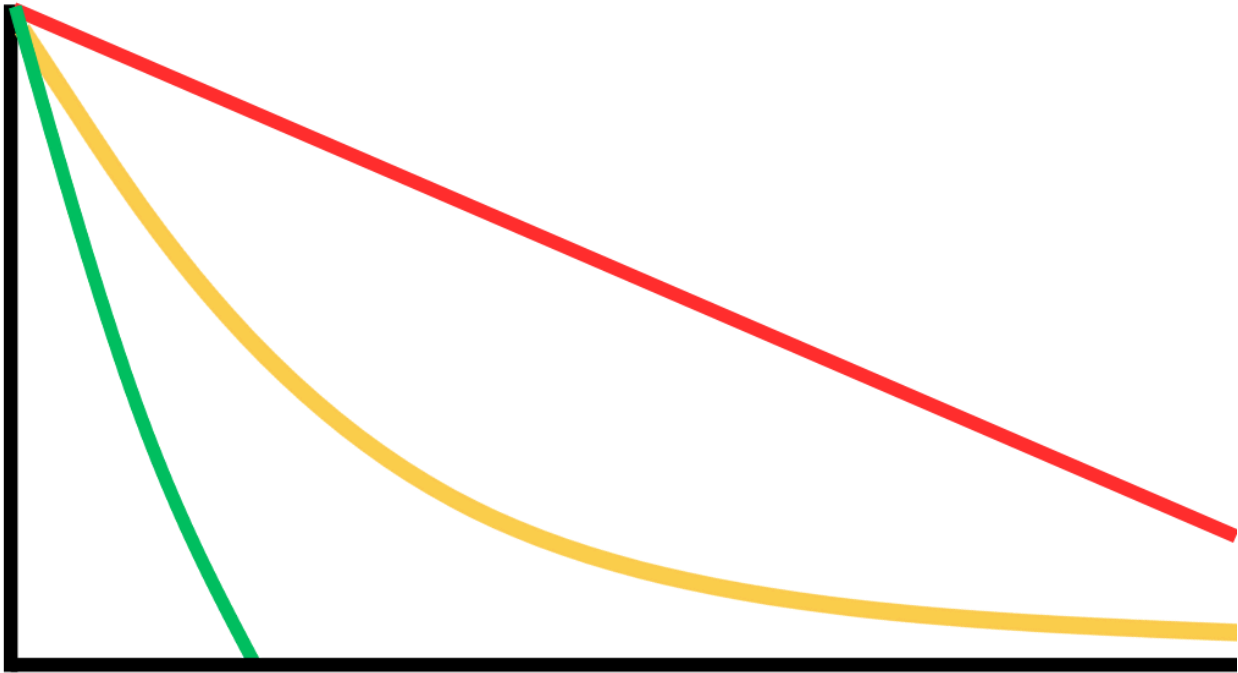

Swath Board Options

Speed Track Kit - set of 13 connecting tracks, engineered to hold paper firmly as drones fly over. Load paper in seconds with innovative sled design. Need more than 52'? No problem - simply order a second Kit and add pieces to create your desired length. 4' sections connect for easy setup and transport, packed in one sturdy, wheeled travel case. All you need is your own standard hand drill and the paper spooler from your Swath Gobbler Kit, and the Speed Track Kit supplies the rest.

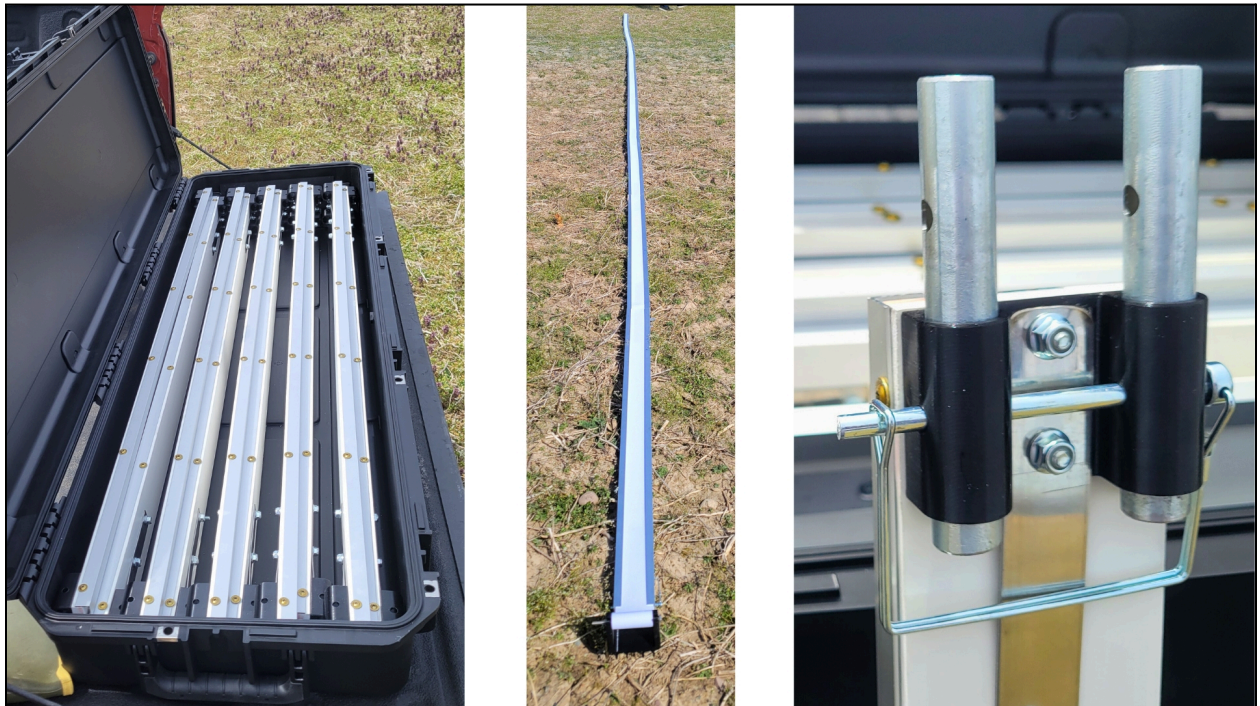

Paper Spooler



If you aren't able to order the Speed Track Kit, vinyl cove molding is a convenient way to make swath boards, which hold the paper collectors flat and stable. By cutting some slits into the sides at regular intervals, you can use rubber bands to attach the collection paper to the vinyl. Once you have finished collecting data, the vinyl can be easily rolled back up for transportation. You can have up to 45 meters in a roll that is still small enough to fly with.



Paper secured to vinyl



Easy to store and transport

4 3 2 1

B

B

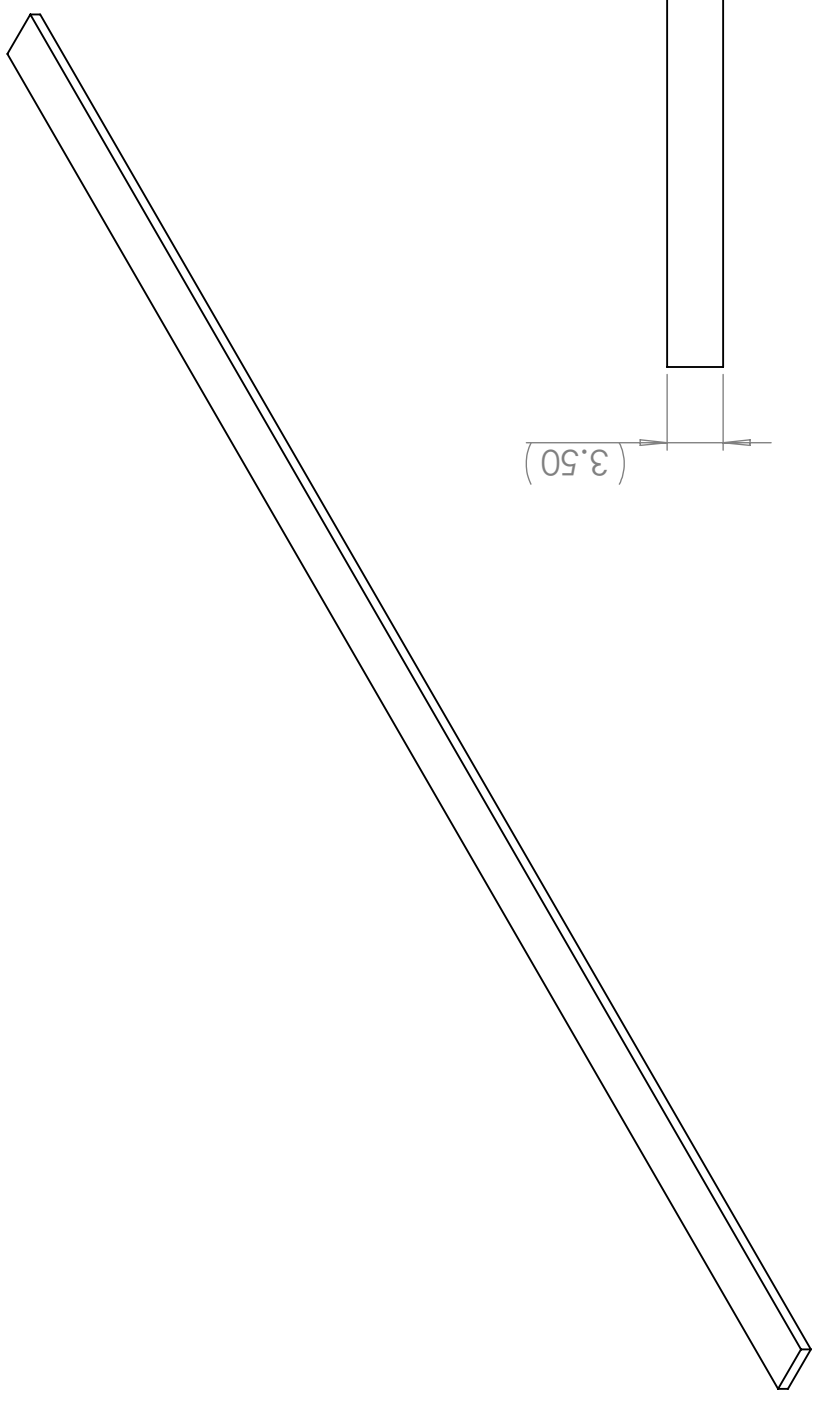

(3.50)

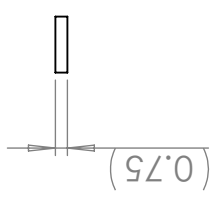

(0.75)

118.00



A

A

PROPRIETARY AND CONFIDENTIAL
 THE INFORMATION CONTAINED IN THIS DRAWING IS THE SOLE PROPERTY OF APPLICATION INSIGHT, LLC. ANY REPRODUCTION IN PART OR AS A WHOLE WITHOUT THE WRITTEN PERMISSION OF APPLICATION INSIGHT, LLC IS PROHIBITED.

UNLESS OTHERWISE SPECIFIED: DIMENSIONS ARE IN INCHES TOLERANCES: FRACTIONAL ± 1/32 ANGULAR: MACH ± 1° TWO PLACE DECIMAL ± .01 THREE PLACE DECIMAL ± .005 BREAK SHARP EDGES .002-.010 INTERPRET GEOMETRIC TOLERANCING PER: MATERIAL FINISH	DRAWN CHECKED ENG APPR. MFG APPR. Q.A. COMMENTS:	NAME SMZ	DATE 2/22/2023	APPLICATION INSIGHT, LLC 400 Business Centre Dr. Suite 11, Lansing, MI 48917 cat@applicationinsight.com (877)410-2363
NEXT ASSY	USED ON	TITLE:		SIZE DWG. NO.
APPLICATION	DO NOT SCALE DRAWING	REV		SHEET 1 OF 1

B long board

4

3

2

1

1

2

3

4

B

B

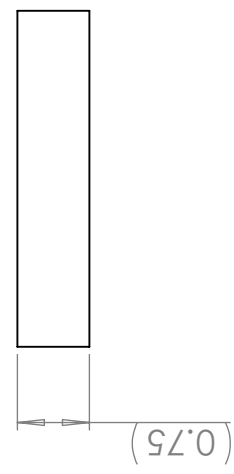
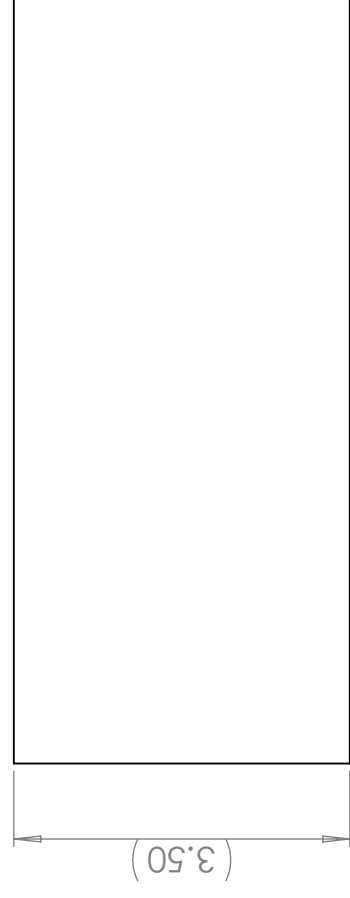
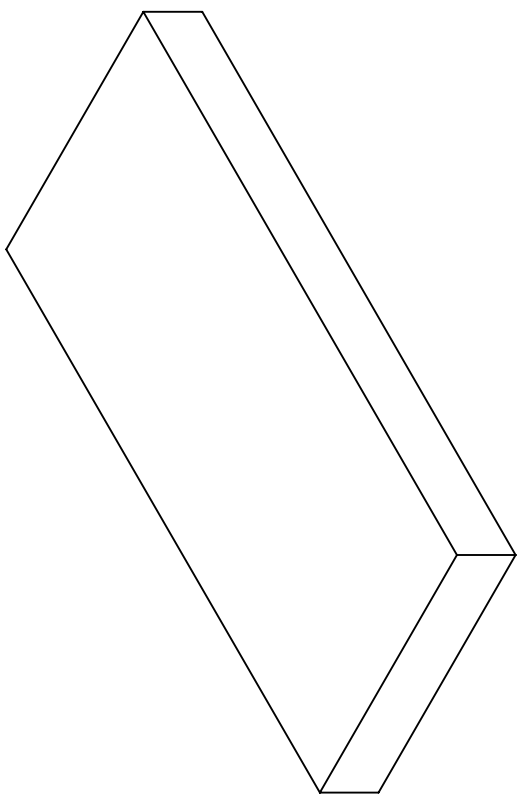

A

A

PROPRIETARY AND CONFIDENTIAL
 THE INFORMATION CONTAINED IN THIS DRAWING IS THE SOLE PROPERTY OF APPLICATION INSIGHT, LLC. ANY REPRODUCTION IN PART OR AS A WHOLE WITHOUT THE WRITTEN PERMISSION OF APPLICATION INSIGHT, LLC IS PROHIBITED.

UNLESS OTHERWISE SPECIFIED: DIMENSIONS ARE IN INCHES TOLERANCES: FRACTIONAL $\pm 1/32$ ANGULAR: MACH $\pm 1^\circ$ TWO PLACE DECIMAL $\pm .01$ THREE PLACE DECIMAL $\pm .005$ BREAK SHARP EDGES .002-.010		DRAWN	NAME	DATE	APPLICATION INSIGHT, LLC 400 Business Centre Dr. Suite 11, Lansing, MI 48917 cat@applicationinsightllc.com (877)410-2363
INTERPRET GEOMETRIC TOLERANCING PER: MATERIAL	CHECKED	SMZ	2/22/2023	TITLE:	REV
FINISH	ENG APPR.				
USED ON	MFG APPR.				
APPLICATION	Q.A.				
DO NOT SCALE DRAWING	COMMENTS:				
NEXT ASSY					

SIZE DWG. NO. **B**
short board
 SCALE: 1:2 WEIGHT: SHEET 1 OF 1

1

2

3

4

4

3

2

1

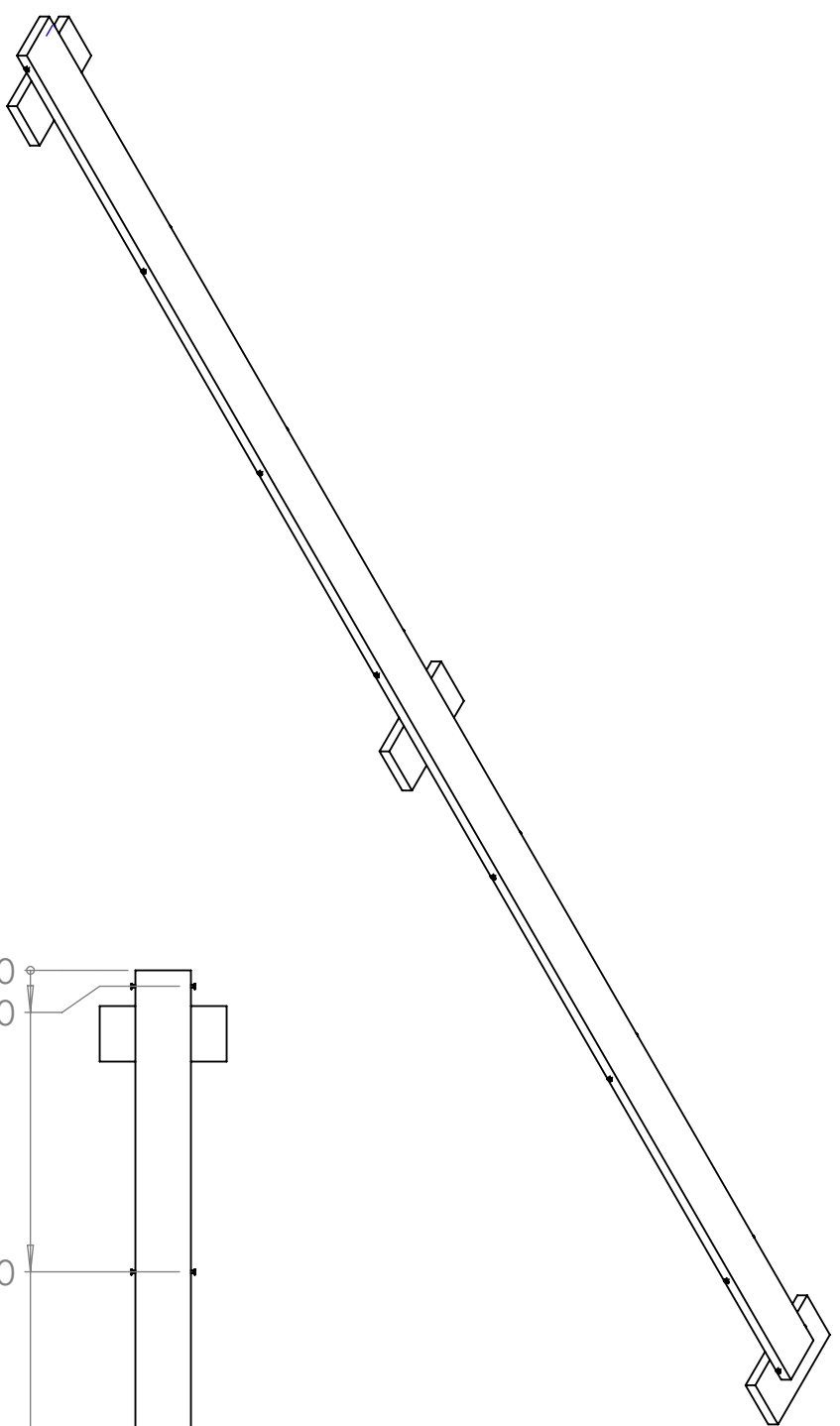

B

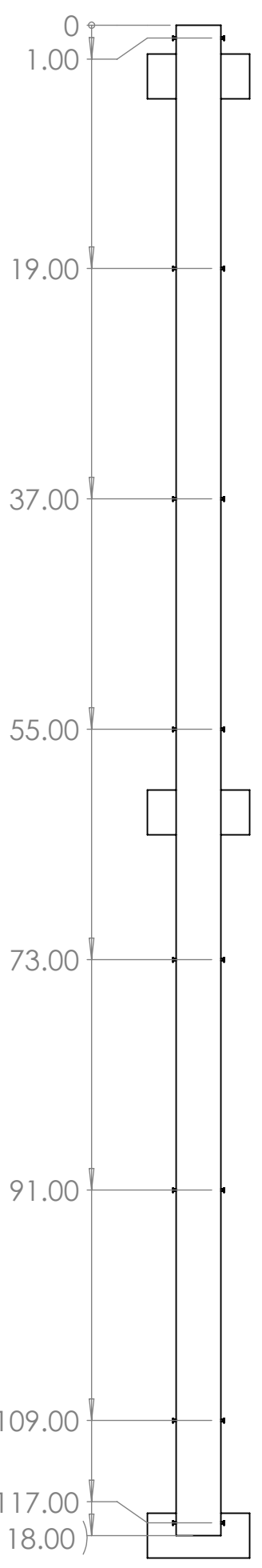

B

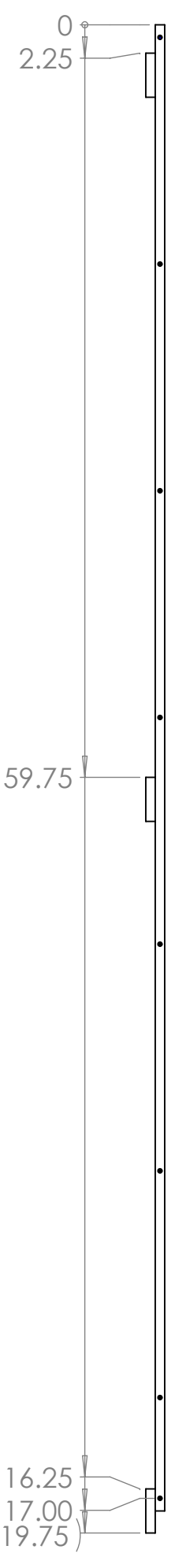
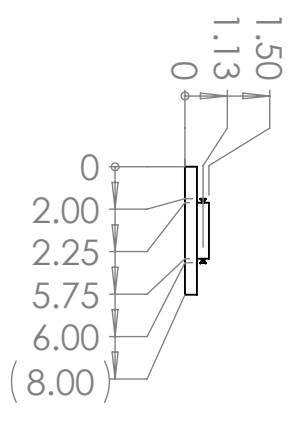

A

A

4

3

2

1

PROPRIETARY AND CONFIDENTIAL
 THE INFORMATION CONTAINED IN THIS
 DRAWING IS THE SOLE PROPERTY OF
 APPLICATION INSIGHT, LLC. ANY
 REPRODUCTION IN PART OR AS A WHOLE
 WITHOUT THE WRITTEN PERMISSION OF
 APPLICATION INSIGHT, LLC IS
 PROHIBITED.

UNLESS OTHERWISE SPECIFIED: DIMENSIONS ARE IN INCHES		NAME	DATE	APPLICATION INSIGHT, LLC. 400 Business Centre Dr. Suite 111, Lansing, MI 48917 cad@applicationinsight.com (877)410-2363	
TOLERANCES: FRACTIONAL ±1/32		DRAWN	SMZ		2/22/2023
ANGULAR: MACH+1°		CHECKED			
TWO PLACE DECIMAL ±.01 THREE PLACE DECIMAL ±.005 BREAK SHARP EDGES .002-.010		ENG APPR.			
INTERPRET GEOMETRIC TOLERANCING PER: MATERIAL		COMMENTS:		QA.	
FINISH		APPLICATION		REV	
NEXT ASSY		USED ON		SIZE DWG. NO.	
DO NOT SCALE DRAWING		TITLE:		Bswath Board	
		SCALE: 1:20 WEIGHT:		SHEET 1 OF 1	